



TORINCAB2 s.r.l.



ΕΚΘΕΣΗ ΔΟΥΔΟΥΔΗ ΠΑΡΚΟ ΟΜΟΝΟΙΑΣ
(ΑΥΤΟΚΙΝΗΤΟΔΡΟΜΙΟ ΣΕΡΡΩΝ) 62125, ΣΕΡΡΕΣ
ΤΗΛ. : 2321059459
www.doudoudis.gr
info@doudoudis.gr

NEW APPROVAL O.E.C.D. CAB FOR TRACTORS:

VALTRA

A53 / A63 / A73

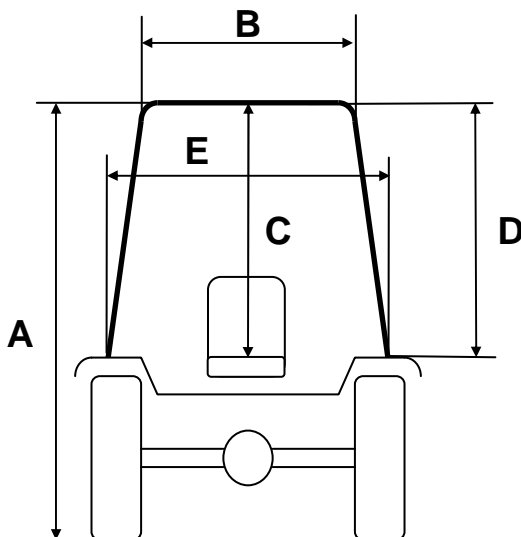

Cabin mounted on VALTRA A73 tractor Back Tyres 340/85 R.28	
A	2300 mm
B	1000 mm
C	1050 mm
D	980 mm
E	1050 mm

TECHNICAL FEATURES:

The cabin is newly designed with the supporting structure approved OECD, made with new rounded profile for recessed closure to the disappearance of the glass windshield and side doors.

The after lateral curved glasses door allows total visibility of the back tool to its full width, eliminating blind spots that derive from the rear pillars of the cab at corner, not more present on the structure. All the windows are open, through the use of gas springs.

The frame can be disassembled and reassembled very quickly thanks to the direct attack on platform of the tractor. On demand it is possible to add air conditioning or only ventilation / heating that will be connected to the motor with quick release to allow disassembly without dispersion of gas / liquid.

The cabin of new conception will be produced to meet the needs of passage in orchards and vineyards. The product that we supply provides the possibility to use the tractor even in situations where there is a lot of slope, thanks to the width of the roof of 100 cm, while maintaining a minimum height (see attached table) and safety features, comfort and quality excellent for the operator inside the cabin in any work situation.

As always, Torincab2 srl, wants to satisfy customers, producing a cabin with particular attention on detail and finishes, example:

- New roof colour METALLIC SILVER with adjustable working lights round recessed (available on request LED) aesthetically and qualitatively better than previous versions.
- Quick cleaning and replacing of the air filter or on request, of the activated carbon filter, executable outside of the cabin instead of inside the cabin as in previous versions.
- Foldaway conditioner in the cabin inspectable manually with rapid cleaning of the radiator / condenser.
- Hermetic closure of the cabin through sealing that completely eliminate the intrusion of dust or chemical and meteorological agents inside the cockpit cabin allowing the pressurization of the cabin for the optimal use of air conditioning, allowing a situation of well-being even during the hottest periods of the year.

